

4

3

2

1

PARTS LIST

PARTS LIST SELECTION BASED ON DRUM SIZE

PARTS LIST SELECTION BASED ON MOTOR FRAME SIZE

ITEM	QTY	PART NUMBER	DESCRIPTION
1	1		MOTOR, PER CUSTOMER SPECIFICATIONS
3	1	SEE CHART	ASSEMBLY, COUPLER, TO 5/16 HEX
5	1	2A2100R8	ADAPTER, 56C/145TC, XFG
6	1	SEE CHART	WELDMENT, DRUM, XFG
8	3	SEE CHART	TIE ROD, XFG
9	1	SEE CHART	HEX SHAFT, 1/2, 12L14
10	1	2A16154R0	LABEL, COLUMBIA UNIT
12	1	03-23667	FREESPOOL BLOCKOUT, XFG
13	1	03-36974	SET SCREW - EXT POINT, M10-1.5X12
14	1	03-91403	GEAR, HOIST CLUTCH, XFG
15	1	03-31684	GEAR HOUSING, XG
16	1	03-31679	RING GEAR, XG
17	2	03-31675	DRUM SUPPORT, XFG
19	1	03-30335	ASSEMBLY, CARRIER (6.00:1)
22	2	03-30277	WASHER, THRUST, XFG
23	2	03-30275	SEAL, DRUM, XFG
24	2	03-30274	BUSHING, DRUM, XFG
25	1	03-16149	GEAR, SUN
26	1	03-24563	ASSEMBLY, CARRIER (6.00:1)
27	1	03-16086	FS RETAINER, XG
29	2	03-15581	RETAINING RING
30	3	03-14964	GASKET, XFG
31	6		SHCS, 3/8-16X1-1/4, PLTD
32	4		SHCS, 3/8-16X3/4, PLTD
33	10		SHCS, 1/4-20X3, PLTD
34	10		SHCS, 1/4-20X1-1/4, PLTD
35	1	2A14472R0	DECAL, 3", COLUMBIA WINCH AND HOIST

ITEM	DRUM SIZE	QTY	PART NUMBER	DESCRIPTION
6	-01	1	2A6493R4	WELDMENT, DRUM, XFG-01
6	-02	1	03-31671	WELDMENT, DRUM, XFG-02
6	-03	1	2A6265R5	WELDMENT, DRUM, XFG-03
6	-19	1	2A8515R6	WELDMENT, DRUM, XFG-19
8	-01	3	03-30338	TIE ROD, XFG-01
8	-02	3	03-30268	TIE ROD, XFG-02
8	-03	3	03-31288	TIE ROD, XFG-03
8	-19	3	2A12190R1	TIE ROD, XFG-19
9	-01	1	2A16731R0	HEX SHAFT, 1/2X13.375", 12L14
9	-02	1	2A16729R0	HEX SHAFT, 1/2X15.375", 12L14
9	-03	1	2A16732R0	HEX SHAFT, 1/2X17.875", 12L14
9	-19	1	2A16960R0	HEX SHAFT, 1/2X9.875", 12L14
36	-19	5	97654A261	FBHCS, 1/4-20X3/8, SS

ITEM	FRAME	PART NUMBER	DESCRIPTION
3	56C	2A16520R0	ASSEMBLY, COUPLER, Ø5/8 TO 1/2 HEX (56C)
3	145TC	2A16518R0	ASSEMBLY, COUPLER, Ø7/8 TO 1/2 HEX (145TC)

B

B

A

A

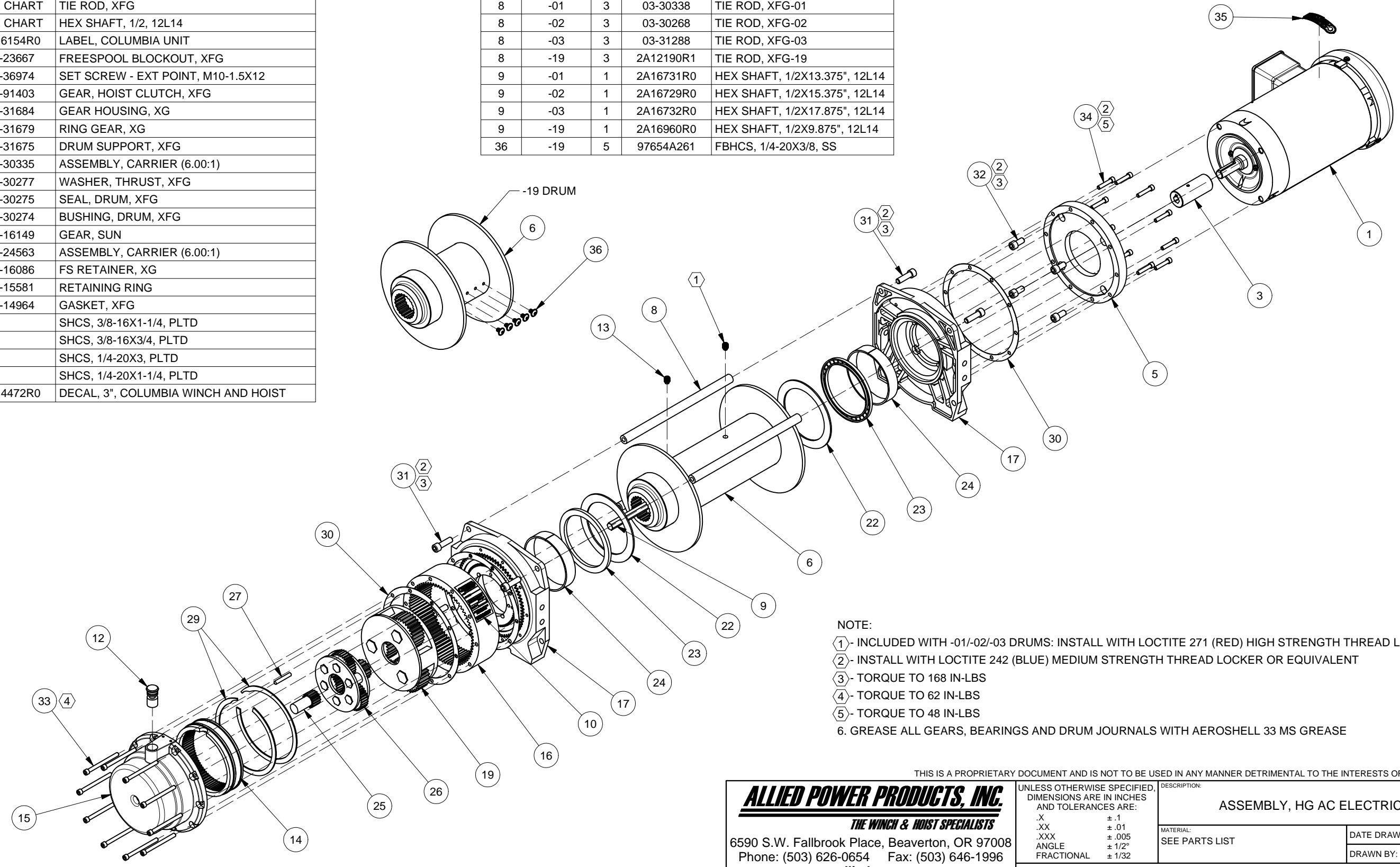

NOTE:
 ① - INCLUDED WITH -01/-02/-03 DRUMS: INSTALL WITH LOCTITE 271 (RED) HIGH STRENGTH THREAD LOCKER OR EQUIVALENT
 ② - INSTALL WITH LOCTITE 242 (BLUE) MEDIUM STRENGTH THREAD LOCKER OR EQUIVALENT
 ③ - TORQUE TO 168 IN-LBS
 ④ - TORQUE TO 62 IN-LBS
 ⑤ - TORQUE TO 48 IN-LBS
 6. GREASE ALL GEARS, BEARINGS AND DRUM JOURNALS WITH AEROSHELL 33 MS GREASE

THIS IS A PROPRIETARY DOCUMENT AND IS NOT TO BE USED IN ANY MANNER DETRIMENTAL TO THE INTERESTS OF ALLIED POWER PRODUCTS, INC.

ALLIED POWER PRODUCTS, INC.
THE WINCH & HOIST SPECIALISTS
 6590 S.W. Fallbrook Place, Beaverton, OR 97008
 Phone: (503) 626-0654 Fax: (503) 646-1996
www.alliedpower.com

UNLESS OTHERWISE SPECIFIED, DIMENSIONS ARE IN INCHES AND TOLERANCES ARE:	
.X	± .1
.XX	± .01
.XXX	± .005
ANGLE	± 1/2°
FRACTIONAL	± 1/32

DESCRIPTION: ASSEMBLY, HG AC ELECTRIC HOISTS (36:1)	
MATERIAL: SEE PARTS LIST	DATE DRAWN: 6/13/2014
LATEST REVISION: ADD DECAL & -19 DRUM - LRN	SHEET 1 OF 1
	DRAWING NUMBER: 2B16728R1

4

3

2

1